

PLAN VIEW

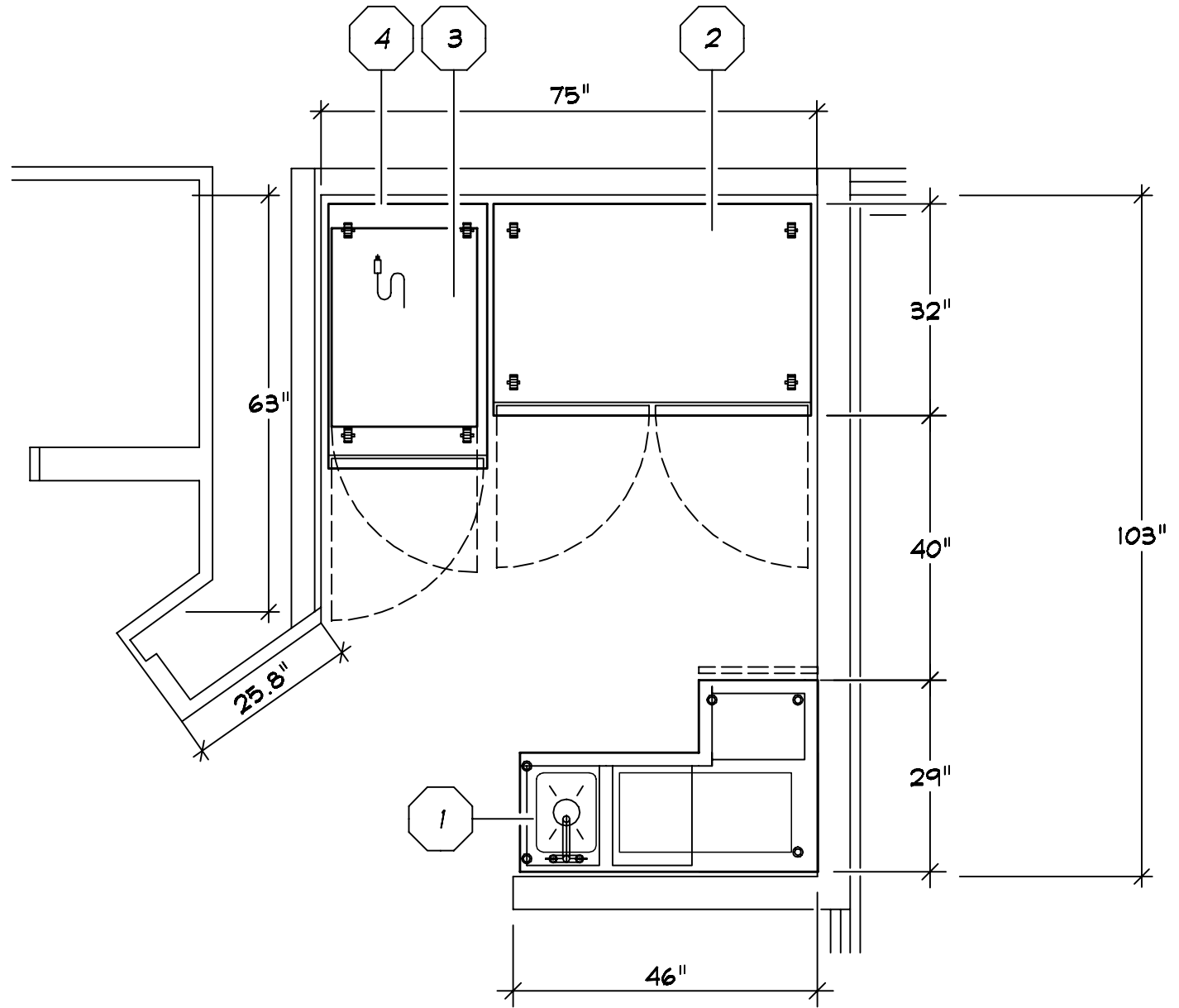

NS-PNT04



NAOMI SOBEL

NS-MTZ PANTRY - 3rd Floor

10-18-21

ITEM: 1      1 EA    WORK STATION  
METAL FABRICATOR

SIZE AND SHAPE PER DETAIL DRAWING

1C COLD WATER - (1) 1\2"

1H HOT WATER - (1) 1\2"

1I WASTE - (1) 3\4"

12 WASTE (1) 1-1\2" SINK

ITEM: 2      1 EA    REFRIGERATED BASE  
BEVERAGE AIR            UCR48AHC

SELF CONTAINED FREEZER

ON CASTERS

FRONT BREATHING

UNDERCOUNTER CLEARANCE

SOLID SST TOP

SIZE AND SHAPE PER DRAWING

2E POWER - 120-1 CIRCUIT, 7.0 AMP, NEMA 5-15,  
RI 18" AFF, (1) REFRIGERATED BASE

ITEM: 3      1 EA    H SERIES COMBI  
ALTO SHAAM

3E POWER - 208-1 CIRCUIT, 38.0 AMP,  
NEMA 6-50, RI 40" AFF, (1) H SERIES COMBI

ITEM: 4      1 EA    REFRIGERATOR  
CUSTOM MFG

24" X 40" X 32" HIGH

SELF CONTAINED

MEDIUM TEMP

ON 3 CASTERS

SIZE AND SHAPE PER DRAWING

4E POWER - 120-1 CIRCUIT, 7.0 AMP, NEMA 5-15,  
RI 18" AFF, (1) REFRIGERATOR

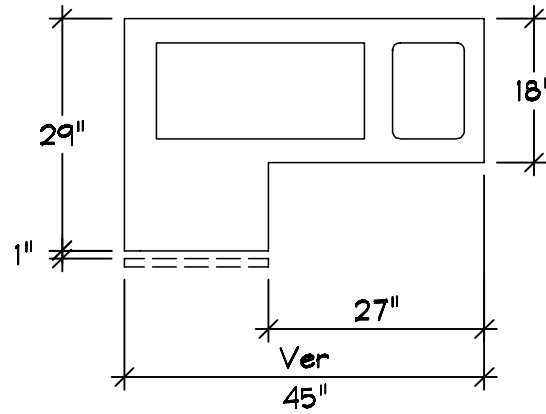
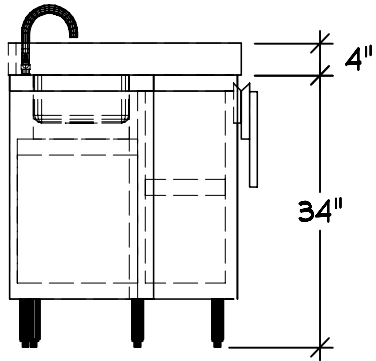

ITEM NUMBER : 1  
 QTY : 1 EA  
 MFG : METAL FABRICATOR  
 DESCRIP : WORK TABLE

TOP: 16 GA TYPE 304 SST  
 SPLASHES: (2) REAR

LEGS: 6" SST BULLET FEET  
 ADJUSTABLE HEIGHTS

BASE: 18 GA SST  
 MECHAICAL ACCESS  
 4" X 1" SST SPLASH

OPTIONS:

- (1) HAND SINK  
 9 X 12 X 5" DEEP  
 DUAL CONTROL FAUCET
- (1) INSULATED ICE BIN  
 REMOVABLE LID  
 26 X 12 X 10" DEEP  
 3/4" DRAIN
- (1) FOLDING END SHELF  
 18 X 12  
 SIZE AND SHAPE PER DRAWING

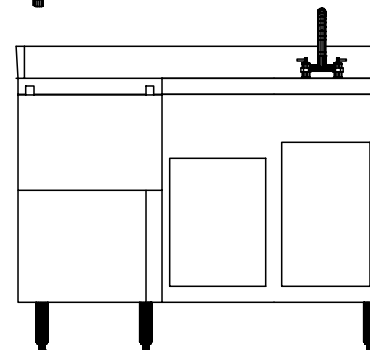
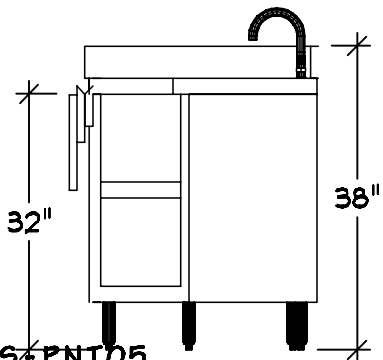
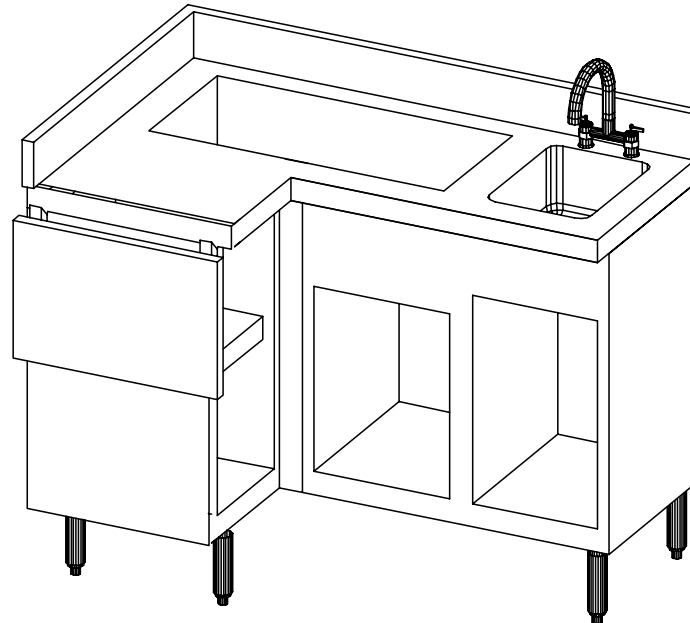

PLUMBING	CW: (1) 0.5"
	HW: (1) 0.5"
	WASTE: (2) 1.5" INDIRECT

NS-PNT05



NAOMI SOBEL

ITEM DETAIL

NS-MTZ PANTRY - 3rd Floor

10-18-21

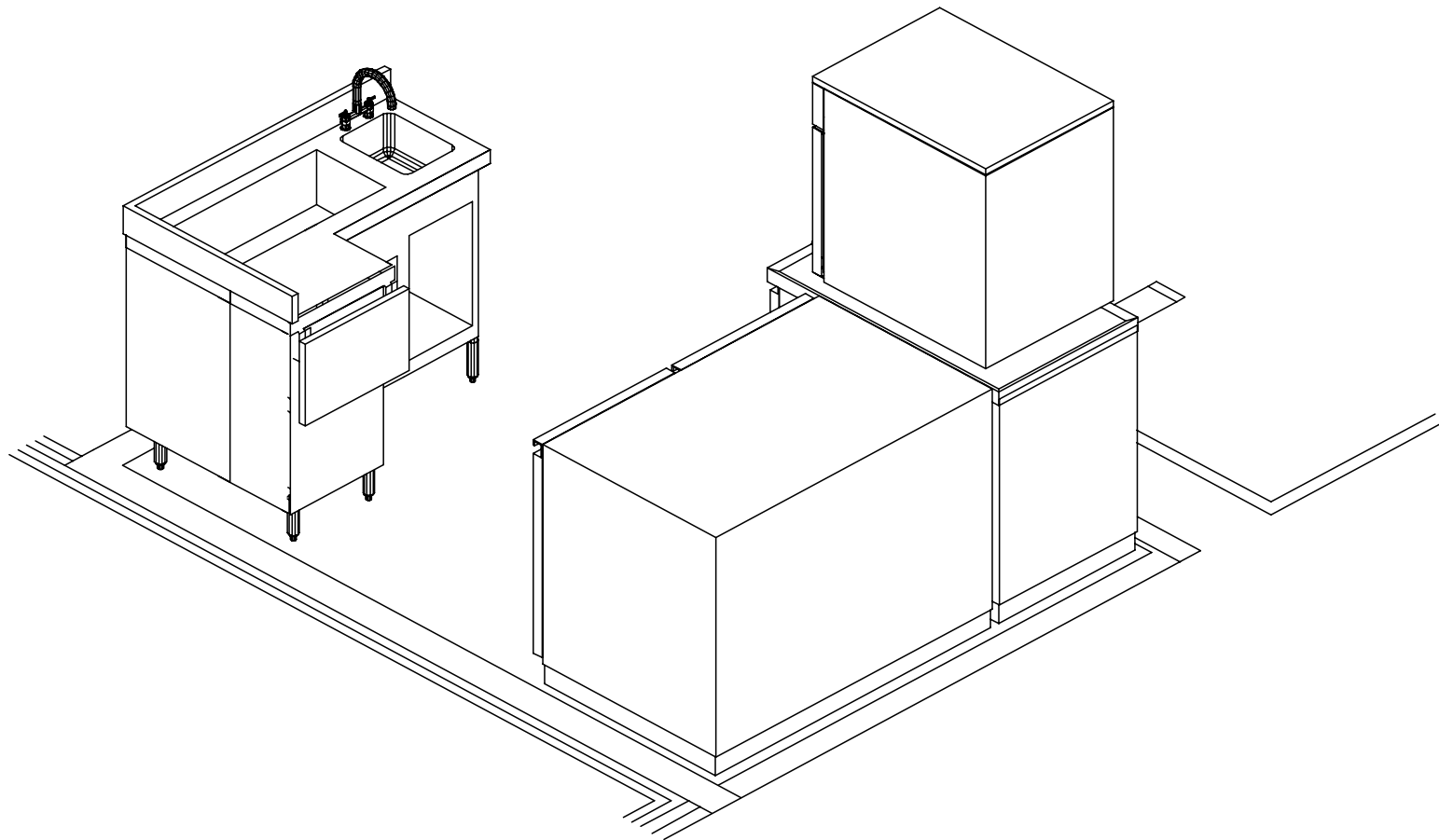

NS-PNT05



NAOMI SOBEL

**NS-MTZ PANTRY - 3RD FLOOR**

NE VIEW

10-18-21

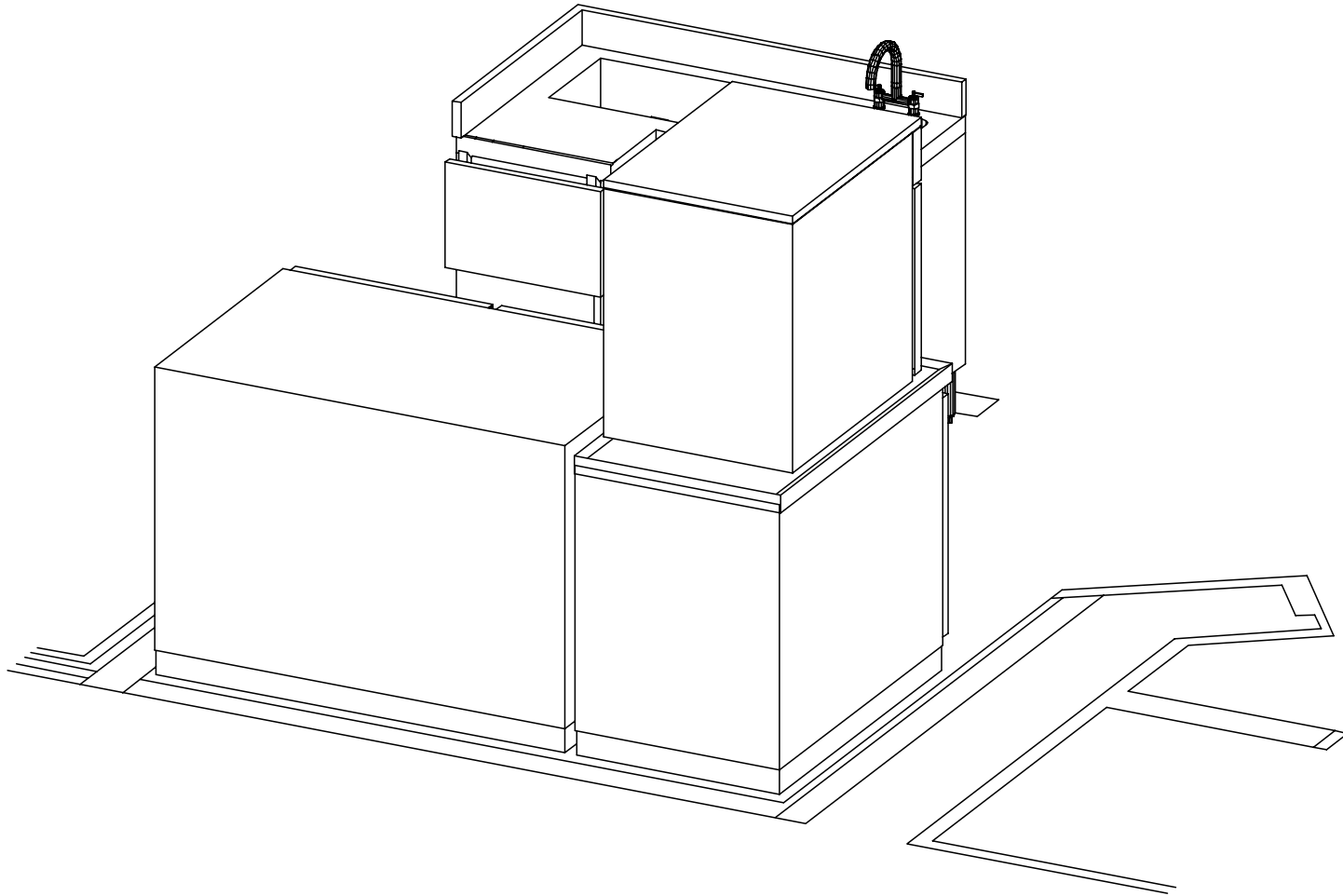

NS-PNT05



NAOMI SOBEL

**NS-MTZ PANTRY - 3RD FLOOR**

NNW VIEW

10-18-21

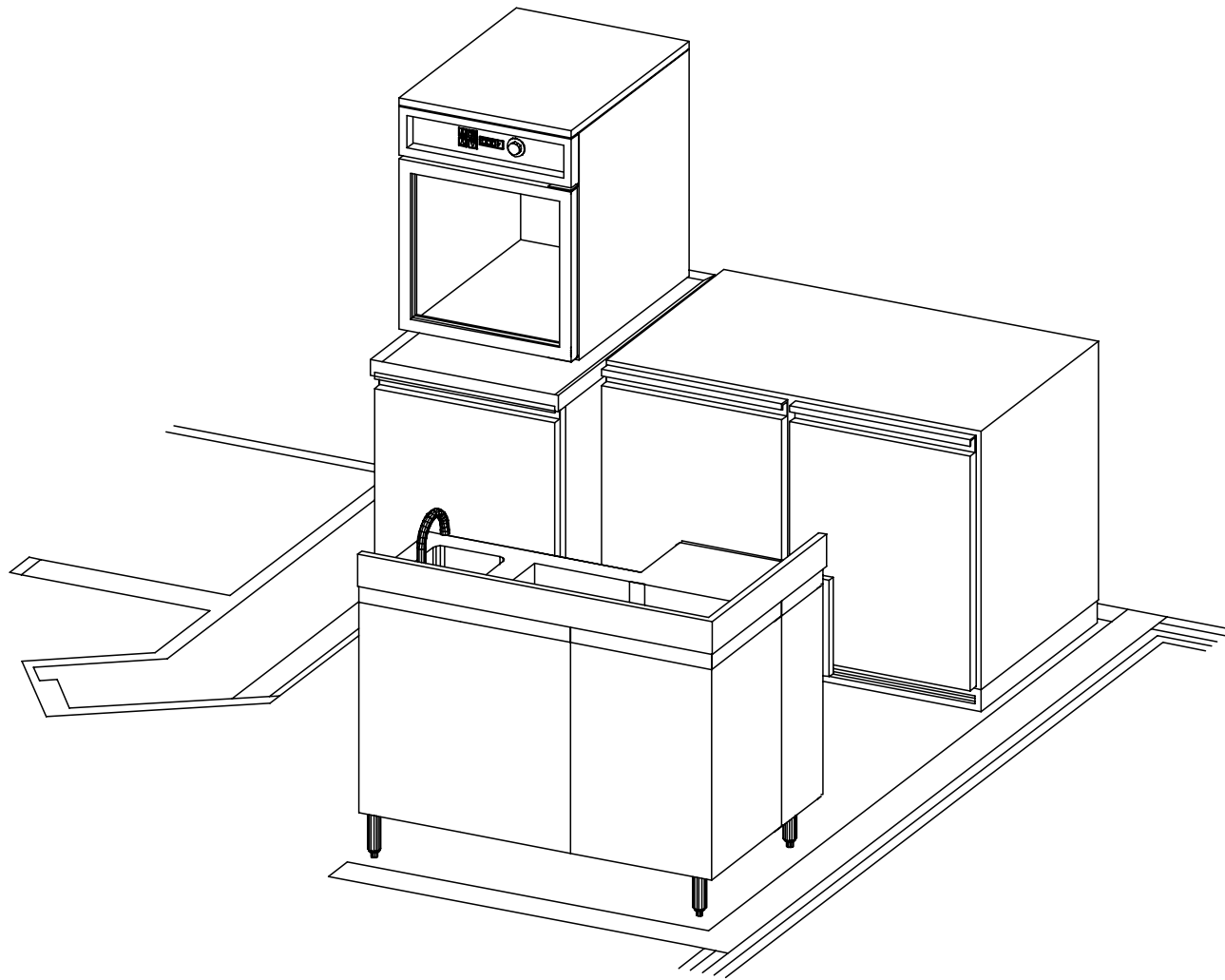

NS-PNT05

*FDi*

NAOMI SOBEL

**NS-MTZ PANTRY - 3RD FLOOR**

*SSE VIEW*

10-18-21

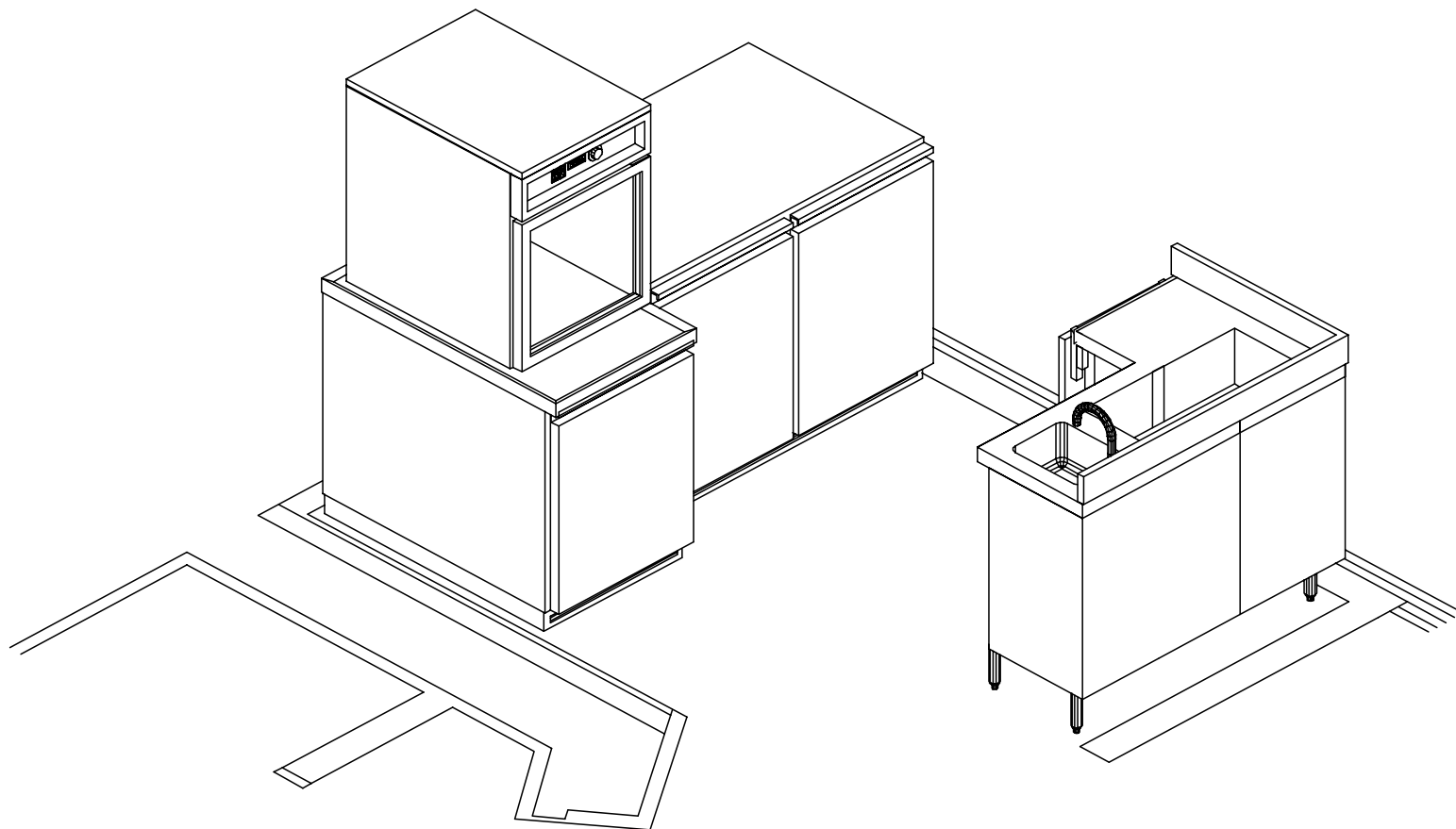

NS-PNT05



NAOMI SOBEL

**NS-MTZ PANTRY - 3RD FLOOR**

SW VIEW

10-18-21