

PLAN VIEW

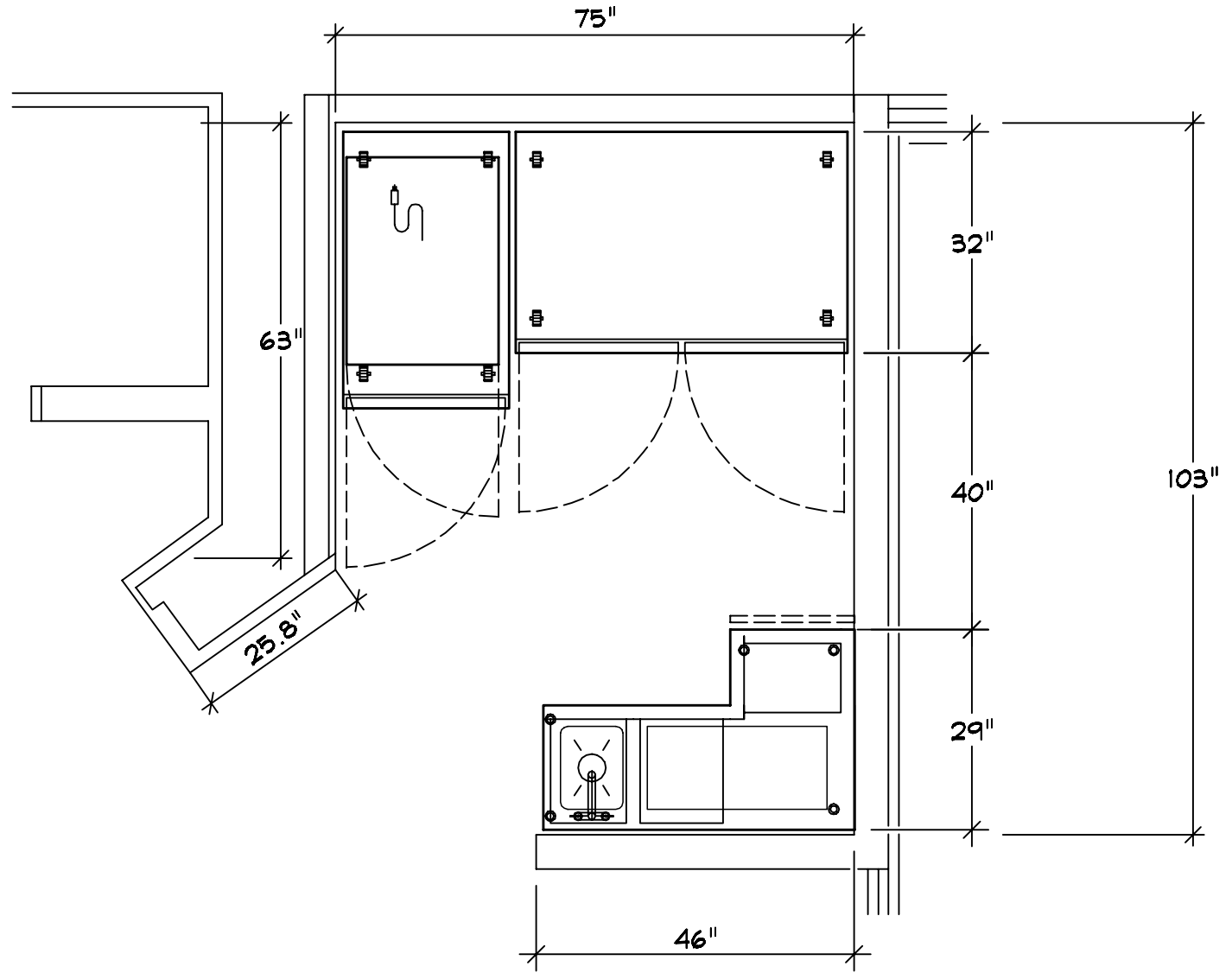

NS-PNT03



NAOMI SOBEL

NS-MTZ PANTRY - 3rd Floor

10-18-21

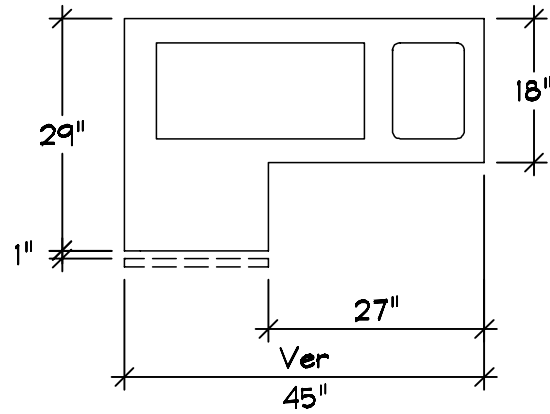
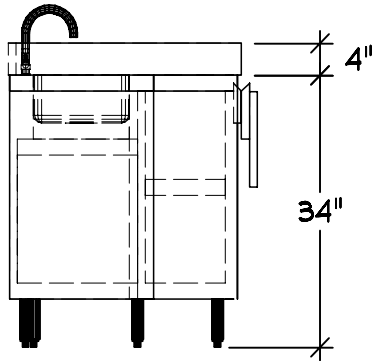

ITEM NUMBER : 1
 QTY : 1 EA
 MFG : METAL FABRICATOR
 DESCRIP : WORK TABLE

TOP: 16 GA TYPE 304 SST
 SPLASHES: (2) REAR

LEGS: 6" SST BULLET FEET
 ADJUSTABLE HEIGHTS

BASE: 18 GA SST
 MECHAICAL ACCESS
 4" X 1" SST SPLASH

OPTIONS:

- (1) HAND SINK
 9 X 12 5" DEEP
 DUAL CONTROL FAUCET
- (1) INSULATED ICE BIN
 REMOVABLE LID
 26 X 12 X 10" DEEP
 34" DRAIN
- (1) FOLDING END SHELF
 18 X 12
 SIZE AND SHAPE PER DRAWING

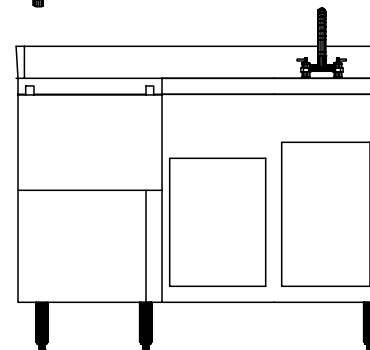
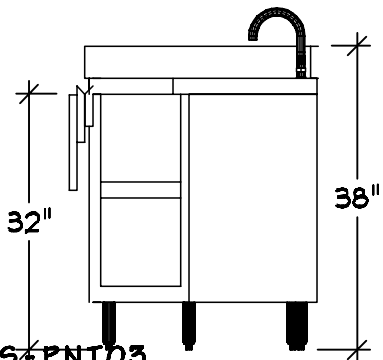
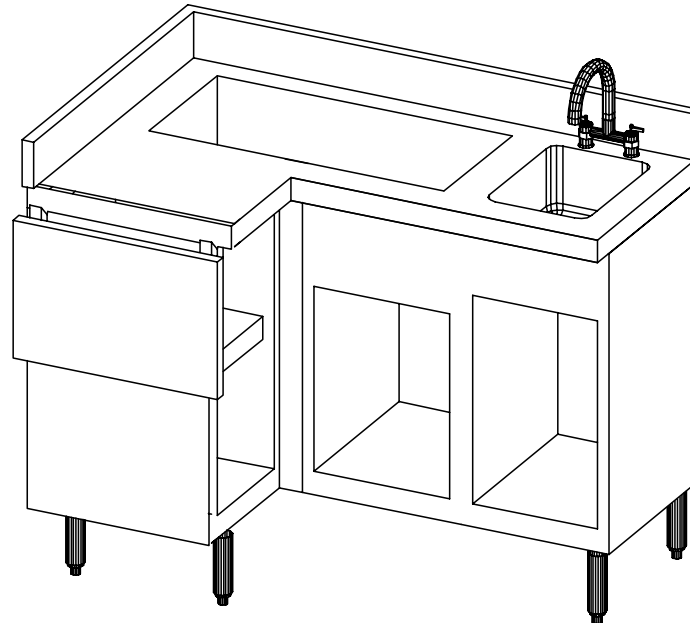

PLUMBING	CW: (1) 0.5"
	HW: (1) 0.5"
	WASTE: (2) 1.5" INDIRECT

NS-PNT03



NAOMI SOBEL

ITEM DETAIL

NS-MTZ PANTRY - 3rd Floor

10-18-21